

zehnder

always the
best climate

Zehnder ComfoAir Q600 ST

Technical specification for comfort ventilation unit



General

Whether you are working on a new build or a renovation project: With a maximum air volume flow of 353 cfm at an external pressure of 0.8" WC, the Zehnder ComfoAir Q600 ST comfort ventilation unit is flexibly suitable for single-family houses and apartment buildings, offices and commercial buildings.

With its new technologies, starting with the diamond heat exchanger, through the revolutionary fan technology for a modulating by-pass and the optional adaptive pre-heater, combined with state-of-the-art control system technology like flow control and active comfort control and a user-friendly operating concept from simple switches to apps, Zehnder ComfoAir Q contributes to a comfortable, healthy and energy-efficient indoor climate.



Zehnder ComfoAir Q600 ST



Zehnder
ComfoSense C67



Zehnder
ComfoSwitch C67



Zehnder
ComfoControl

Benefits

- More heat recovery and less power consumption because of the diamond heat exchanger with a larger surface and lower pressure losses
- Silent and efficient operation via the latest fan technology with RadiCal impeller, flow ring and flow grid
- More comfort via optimal supply temperature via the modulating by-pass with an intelligent temperature controller
- Energy-saving and demand-oriented tempering of outdoor air via adaptive pre-heater (optional)
- Security for planning and installation as one unit combines right and left version
- Simple commissioning and quiet operation with perfectly balanced volume flows because of flow control technology
- User-friendly operation via the tailored operating concept: from an intelligent switch to the app
- Hygienic because of optimal filter concept with filter change wizard
- Avoidance of excessively dry room air because of humidity recovery with the Zehnder enthalpy exchanger (optional)

Technical specifications

Zehnder ComfoAir Q600 ST	
Max. air volume	353 cfm
Height	32" (809 mm)
Total height	33" (850 mm)
Width	29" (725 mm)
Overall width	31" (790 mm)
Depth	22" (570 mm)
Total depth	22.8"/23.4" (580 mm / 595 mm)
Weight	110 lbs (50 kg)
Installation	Wall-mounted / floor-mounted
Temperature range	45°F to 104°F in the installation room
Condensate drain	32 mm external thread
Duct connection (inside/outside)	180 / 200 mm (7.1"/7.9")
Supply voltage	240 V, 60 Hz
Power consumption without/with pre-heater	350 W / 2,620 W
Current draw without/with pre-heater	2.77 A / 12.7 A
Housing	Sheet steel
Designer front panel	ABS, RAL 9003
Inner zone	EPP / ABS
Heat exchanger	PS
Enthalpy exchanger	PE-Copolymer

Passivehaus certification

	HRV	ERV
Component ID	0975vs03	1008vs03
Application [m³/h]	70-460	70-460
Heat recovery efficiency η_{WRG} [-]	87%	80%
Specific electric power consumption $p_{el,spec}$ [W/(m³/h)]	0.24	0.22
Humidity recovery η_X [-]	-	68%

Article numbers

ST = connections on top

Comfort ventilation unit	Article number
ComfoAir Q600 ST HRV	9652-01
ComfoAir Q600 ST ERV	9615-00

Accessories	Article number
ComfoAir Q350/450/600 pre-heater	9656-00
ComfoAir Q350/450/600 mounting base	9573-00
Waterless p-trap	9637-00

Filters	Article number
Filter set for ComfoAir Q350/450/600, G4 / F7 (contains 2 units)	9672-00
Filter for ComfoAir Q350/450/600, G4 (MERV 7/8)	9671-00
Filter for ComfoAir Q350/450/600, F7 (MERV 13)	9670-00

Control units	Article number
ComfoSense C67 control panel	9617-00
ComfoSwitch C67 control panel	9618-00
ComfoConnect LAN C interface	9619-00
ComfoConnect KNX C interface	9655-00
ComfoAir Q350/450/600 option box	9620-00
CO ₂ sensor	9260-01
Humidity sensor	9256-01
Boost switch, momentary contact	9556-00
ComfoSplitter	9647-00

System expansions	Article number
Zehnder ComfoFond-L Q L ST brine-earth heat exchanger, supply air connection left	9658-00
Zehnder ComfoFond-L Q R ST brine-earth heat exchanger, supply air connection right	9657-00

Technologies

Diamond heat exchanger



Unique, ultra-powerful heat exchanger – for maximum energy efficiency

The "diamond" heat exchanger features an especially large surface, which allows it to achieve a higher level of efficiency. Variable duct heights ensure even flow and lower pressure losses, and thus optimal airflow. As a result, less energy is required to overcome the air resistance.

Fans

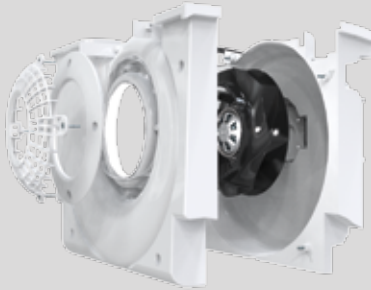

State-of-the-art fan technology – for quiet, energy-saving operation

The flow grid, scroll housing and ebm-papst RadiCal impeller ensure the best possible air flow. This guarantees not only extremely quiet operation, but also particularly low power consumption. A high-quality, future-proof solution, based on tried-and-tested technology.

Modulating by-pass

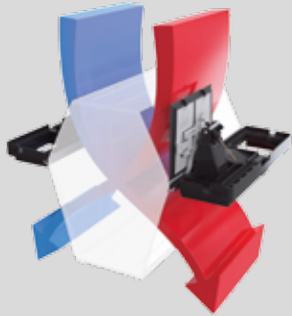

Comfortable indoor ventilation because of intelligent control of the heat recovery

The by-pass controls the exact degree of heat recovery and influences the supply air temperature as a result. The modulating by-pass is guided by an optimum comfort temperature, which is determined on the basis of information from the temperature and humidity sensors as well as an intelligent algorithm.

Pre-heater

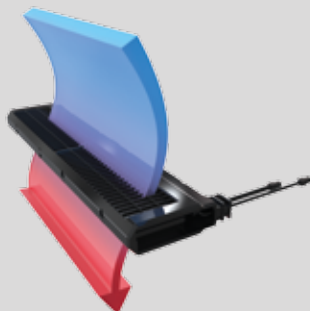

Intelligent temperature control of the drawn-in outdoor air for the best possible energy efficiency

The adaptive pre-heater adapts perfectly to the temperature, volume flow and air humidity, and provides the outside air temperature required for energy-efficient operation no matter what the temperatures are outside. The level of pressure loss is negligible because of its large surface and delta shape – and that also reduces the power consumption.

Sensors

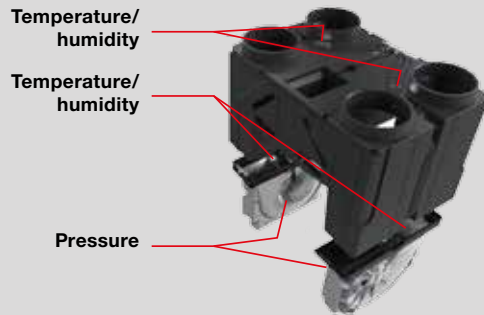

Flawless operation because of intelligent control

Individual sensors continuously determine the temperature, humidity and air pressure in the comfort ventilation unit. This permits precise control of the modulating by-pass, the pre-heater, flow control and humidity comfort mode.

Comfort temperature

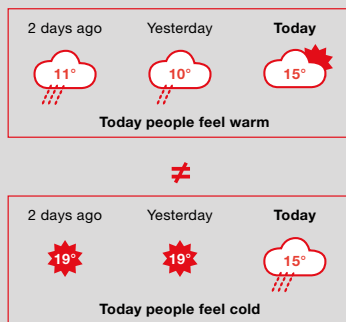

Optimized supply air temperature because of comfort technology

People's temperature sensation depends on the current outdoor temperature and the average outdoor temperatures experienced recently. For this reason, the adaptive climate technology in Zehnder ComfoAir Q adapts the supply air temperature to suit their current needs. As a result, Zehnder ventilation units make an important contribution to ensuring a comfortable indoor climate throughout the year – benefiting your customers.

Filters

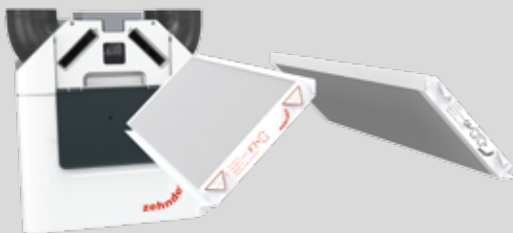

Optimum hygiene because of powerful filters

Completely sealed and maximized, the filters prevent dust from getting into the room air. There is also a programmable warning indicator to show when it is time to replace the filters, ensuring the air is always clean and healthy. The indicator factors in not only the elapsed time, but also the air volume transported.

Flow control



Innovative air volume balancing for maximum heat recovery

New and patented: innovative sensor technology automatically ensures balanced supply air and extract air volumes. This flow control guarantees maximum heat recovery. What's more, you save time during commissioning because there is no need to adjust the speed manually and the air volumes are balanced automatically.

Control options

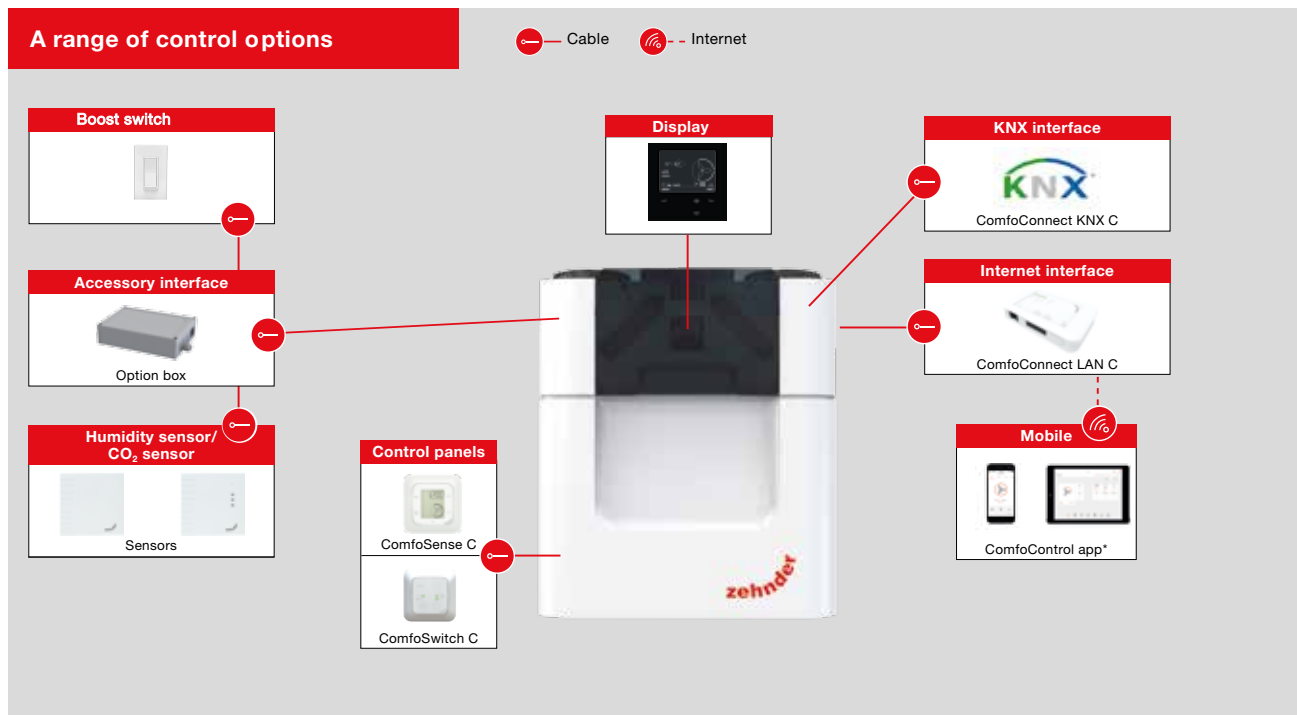

Control panel	Description	Article number	Accessories required
Unit display	Display integrated ex works	-	-
External control panels	ComfoSense C67 control panel ComfoSwitch C67 control panel	9617-00 9618-00	-
Boost switch	momentary contact	9556-00	Option box
Sensor (wired, 0 - 10 V control output)	CO ₂ sensor Humidity sensor	9260-01 9256-01	Option box
App control and web portal**	ComfoConnect LAN C interface	9619-00	Internet access + router with WiFi access
Connection to KNX network	ComfoConnect KNX C interface	9655-00	

All components can be combined with one another. If there are more than four components, a Zehnder ComfoSplitter (9647-00) is required.
* Internet access and a router with WiFi access are required for connection

Control functions

Comfort ventilation unit
Commissioning wizard
Filter change wizard
Real time information for energy saving/consumption
Adaptive comfort temperature control
Flow control technology, constant volume and constant speed control
4 levels, party and absence settings
Weekly time schedule
Control for a modulating electric preheater
Supply and extract air can be set and deactivated separately
Frost protection function
Program setting: fire place

Option box
Control for ComfoFond-L Q brine-earth heat exchanger
Power-on and power-off delay for bathroom switch
Demand control (CO ₂ sensor, humidity sensor)

Tender specification

Zehnder ComfoAir Q600 ST ventilation unit with integrated display

The Zehnder ComfoAir Q600 ST is a centralized, compact ventilation unit with heat recovery and integrated adaptive summer by-pass. This ventilation unit is ideal for new builds as well as for renovation projects.

The housing, made of galvanised or painted sheet steel, is acoustically and thermally insulated. Economical DC fans with RadiCal impeller, flow ring and flow grid ensure economical operation and therefore permit a high level of electrical efficiency. Supply and extraction fans can be controlled separately and can be precisely adjusted to within one percent by entering the balance air volume.

The core of Zehnder ComfoAir Q600 ST is the plastic cross-counterflow heat exchanger with up to 95% heat recovery. It is operated via the integrated control panel. Optionally, it can be operated via a wired control panel (ComfoSense C or ComfoSwitch C), which is connected to the ventilation unit with a cable provided on site (JYSTY 2x2x0.6). It can also be operated via the Zehnder ComfoConnect LAN C or ComfoConnect KNX C interfaces. All working conditions and error messages can be read from the display.

Zehnder ComfoAir Q600 ST is delivered ready to plug in and use. The filters can be replaced easily from the front by the user without opening the unit. The Zehnder ComfoAir Q600 ST can be either wall-mounted or floor-mounted with an optionally available base. It is connected via 4 x 180 mm (7.1") pipe connections at the top of the unit.

- Automatic frost protection regulation - Filter replacement display
 - Automatic and temperature-controlled by-pass
 - Fault history including the last three error messages
 - Supply and extraction fans can be activated separately
 - Comfort temperature controller
 - Program setting: fire place
 - Heat exchanger: PE-Copolymer
 - Fans: EC DC fans, radial, suction side
 - Filters:
 - Extract air: G4 (MERV 7-8)
 - Outdoor air: F7 (MERV 13)
 - Condensate drain: 32 mm
 - Air duct connections: 4x 180 mm (7.1") on top
 - Mains power supply: 240 V, 60 Hz
 - Temperature range: 45 °F to 104 °F in the installation room
 - Sound power (min./max.):
 - Extract air: 43.0 dB(A) / 61.0 dB(A)
 - Supply air: 54.0 dB(A) / 75.0 dB(A)
 - Waste heat recovery efficiency: up to 90%
 - Volume flow:
 - max. 353 cfm (600 m³/h) at 0.8" WC (200 Pa) external
 - min. 25 cfm (42 m³/h) at 0.04" WC (10 Pa) external
- Power consumption:
 - Maximum 345 watt
 - Electrical efficiency:
 - 0.45 W/cfm at 144 cfm
 - Dimensions:
 - Height: with connector 33"
 - Width: with connector 29"
 - Depth: 22"
 - Type: ZE ComfoAir Q600 ST ventilation unit with integrated display
 - Brand: Zehnder Comfosystems

Sound specifications

Sound, pressure side (supply air/exhaust air)*

Measurement point	[cfm]	["WC]	63 Hz [dB]	125 Hz [dB]	250 Hz [dB]	500 Hz [dB]	1,000 Hz [dB]	2,000 Hz [dB]	4,000 Hz [dB]	8,000 Hz [dB]	Total [dB(A)]
1	147	0.1	62.7	57.7	58.4	50.9	46.1	43.1	35.7	24.9	53.9
2	177	0.1	64.4	59.4	60.6	53.7	48.5	45.9	39.3	29.2	56.4
3	206	0.2	66.6	61.6	63.5	57.2	51.5	49.3	43.8	34.4	59.5
4	235	0.2	68.3	63.3	65.7	60.0	53.9	52.1	47.3	38.6	62.0
5	247	0.2	69.0	64.0	66.6	61.1	54.8	53.2	48.8	40.3	63.0
6	265	0.4	70.6	65.6	68.8	63.8	57.2	55.9	52.2	44.4	65.5
7	294	0.4	72.3	67.3	71.0	66.5	59.5	58.6	55.7	48.6	68.1
8	353	0.4	75.8	70.8	75.6	72.1	64.3	64.2	62.9	57.0	73.5
9	265	0.6	71.2	66.2	69.6	64.8	58.0	56.9	53.5	45.9	66.4
10	265	0.8	71.8	66.8	70.4	65.7	58.8	57.8	54.7	47.4	67.4
11	294	0.8	73.4	68.4	72.5	68.3	61.0	60.4	58.0	51.2	69.8
12	353	0.8	67.7	71.7	76.8	73.6	65.6	65.6	64.8	59.3	74.9

Sound, suction side (extract air/outdoor air)*

Measurement point	[cfm]	["WC]	63 Hz [dB]	125 Hz [dB]	250 Hz [dB]	500 Hz [dB]	1,000 Hz [dB]	2,000 Hz [dB]	4,000 Hz [dB]	8,000 Hz [dB]	Total [dB(A)]
1	147	0.1	56.1	51.1	48.9	38.8	31.7	27.4	21.2	19.4	43.2
2	177	0.1	58.0	53.0	50.8	41.5	33.6	29.5	23.7	20.5	45.3
3	206	0.2	60.3	55.3	53.2	44.8	36.1	32.1	26.8	21.9	47.8
4	235	0.2	62.2	57.2	55.1	47.4	38.0	34.1	29.3	23.0	49.9
5	247	0.2	63.0	58.0	55.8	48.5	38.8	35.0	30.3	23.4	50.8
6	265	0.4	64.8	59.8	57.7	51.0	40.7	37.0	32.7	24.5	52.8
7	294	0.4	66.7	61.7	59.5	53.6	42.6	39.0	35.1	25.5	55.0
8	353	0.4	70.5	65.5	63.3	59.0	46.5	43.2	40.2	27.7	59.4
9	265	0.6	65.5	60.5	58.3	52.0	41.4	37.7	33.6	24.8	53.6
10	265	0.8	66.1	61.1	59.0	52.9	42.0	38.4	34.4	25.2	54.4
11	294	0.8	67.9	62.9	60.7	55.3	43.8	40.3	36.7	26.2	56.4
12	353	0.8	71.5	66.5	64.3	60.3	47.5	44.3	41.5	28.3	60.6

Housing radiation, installation room*

Measurement point	[cfm]	["WC]	63 Hz [dB]	125 Hz [dB]	250 Hz [dB]	500 Hz [dB]	1,000 Hz [dB]	2,000 Hz [dB]	4,000 Hz [dB]	8,000 Hz [dB]	Total [dB(A)]
1	147	0.1	52.0	47.0	47.6	40.9	36.0	31.5	24.9	20.1	43.4
2	177	0.1	53.2	48.2	49.3	43.3	37.9	34.0	28.1	22.9	45.4
3	206	0.2	54.8	49.8	51.4	46.2	40.4	37.2	32.1	26.3	48.0
4	235	0.2	56.1	51.1	53.0	48.6	42.4	39.7	35.4	29.1	50.0
5	247	0.2	56.6	51.6	53.7	49.6	43.2	40.7	36.7	30.2	50.9
6	265	0.4	57.9	52.9	55.3	51.8	45.1	43.2	39.8	32.9	53.0
7	294	0.4	59.1	54.1	56.9	54.1	47.0	45.7	43.0	35.7	55.2
8	353	0.4	61.7	56.7	60.2	58.9	51.0	50.8	49.5	41.3	59.7
9	265	0.6	58.3	53.3	55.9	52.6	45.8	44.1	40.9	33.9	53.8
10	265	0.8	58.8	53.8	56.5	53.5	46.5	45.0	42.1	34.9	54.5
11	294	0.8	60.0	55.0	58.0	55.6	48.3	47.3	45.0	37.4	56.6
12	353	0.8	62.4	57.4	61.1	60.1	52.0	52.2	51.2	42.7	60.9

* Housing radiation measured per ISO 3741:2010
Lw in dB(A) at reference power 10⁻¹²W

Performance data

Performance data*								
Measurement point	[cfm]	["WC]	P [W]	cos ϕ	SFP [W/cfm]	Lw, pressure side [dB(A)]	Lw, suction side [dB(A)]	Lw, housing [dB(A)]
1	147	0.1	28	0.48	0.19	53.9	43.2	43.4
2	177	0.1	44	0.51	0.25	56.4	45.3	45.4
3	206	0.2	72	0.54	0.36	59.5	47.8	48.0
4	235	0.2	97	0.55	0.41	62.0	49.9	50.0
5	247	0.2	108	0.56	0.44	63.0	50.8	50.9
6	265	0.4	144	0.57	0.54	65.5	52.8	53.0
7	294	0.4	177	0.59	0.59	68.1	55.0	55.2
8	353	0.4	255	0.61	0.73	73.5	59.4	59.7
9	265	0.6	163	0.58	0.61	66.4	53.6	53.8
10	265	0.8	182	0.59	0.68	67.4	54.4	54.5
11	294	0.8	217	0.60	0.73	69.8	56.4	56.6
12	353	0.8	298	0.62	0.85	74.9	60.3	60.9

* SFP in W/cfm calculated per EN13141-7:2010
cos phi with pre-heater deactivated

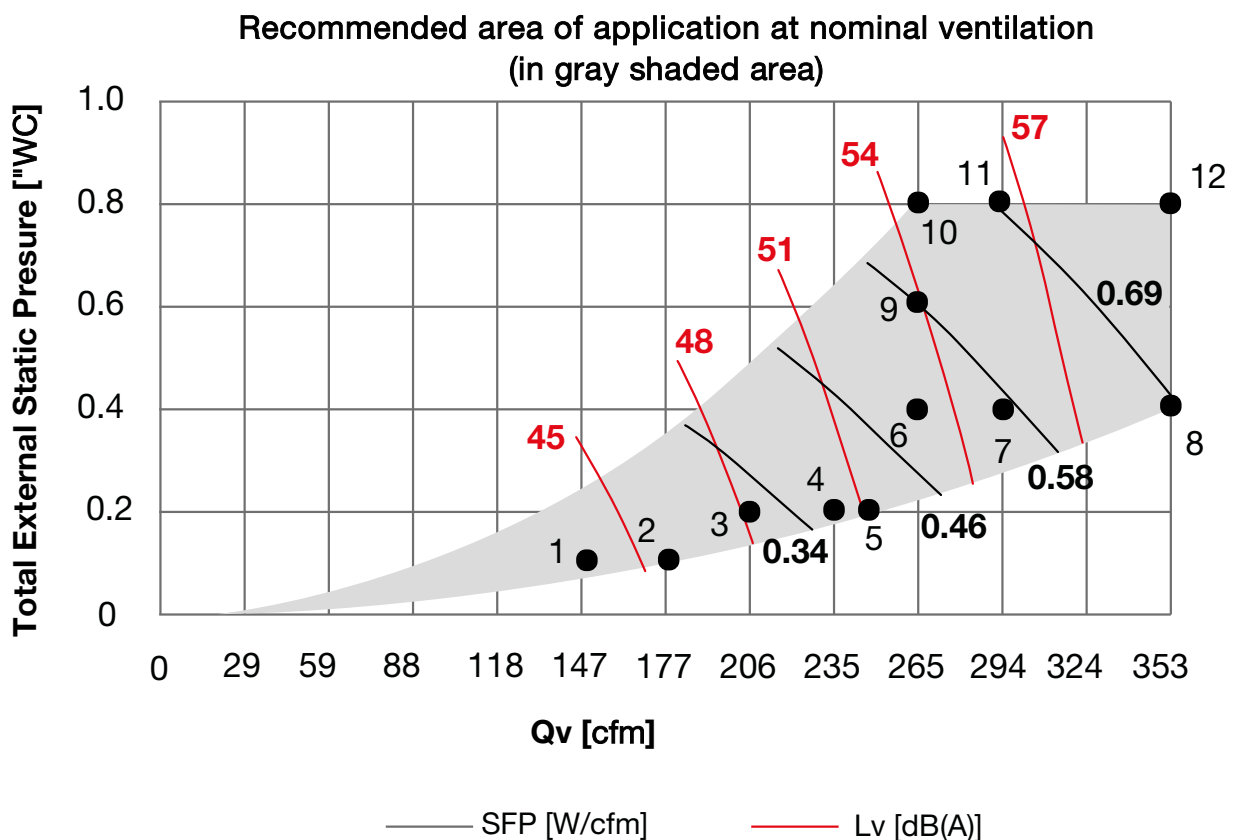

Zehnder ComfoAir Q350/Q450/Q600

ERV Core Performance

(Enthalpy Exchanger 370-H500-S)

Pressure Drop (core only)

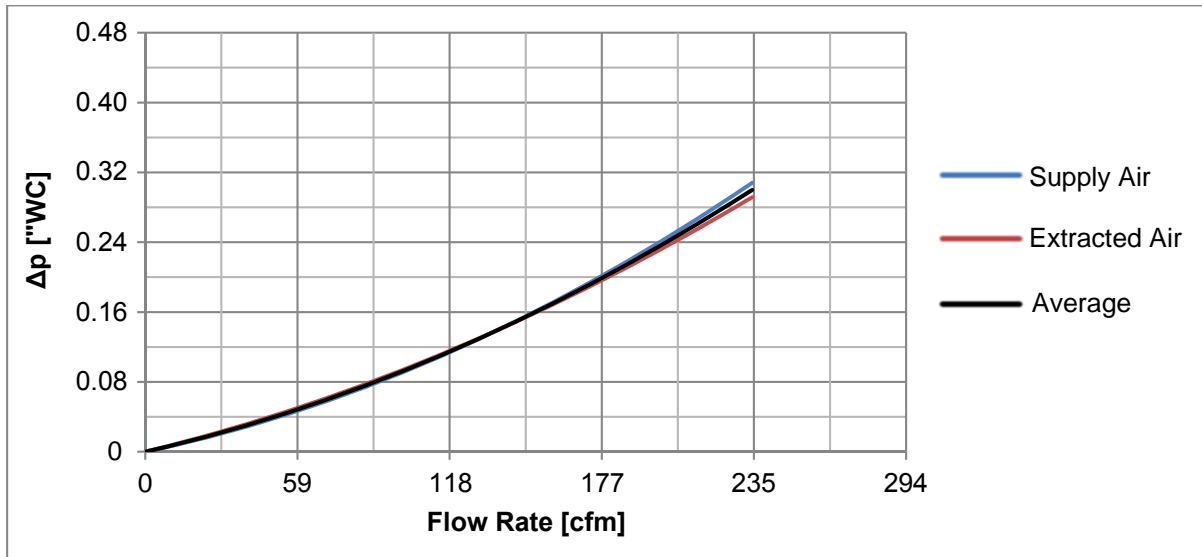

Recovery Efficiency (core only)

Flow Rate [cfm]	59	118	177	235
Sensible Recovery Efficiency [%]				
Supply	90.3	84.6	79.8	76.2
Extracted	87.6	82.3	78.4	74.9
Average	88.9	83.4	79.1	75.5
Latent Recover Efficiency [%]				
Supply	81.5	69.5	61.0	54.6
Extracted	82.5	71.3	64.0	58.2
Average	82.0	70.4	62.5	56.4
Enthalpy Recovery Efficiency [%]				
Supply	86.3	77.8	71.3	66.3
Extracted	85.4	77.6	72.1	67.6
Average	85.9	77.7	71.7	66.9

Zehnder ComfoAir Q350/Q450/Q600

HRV Core Performance

(Heat Exchanger (with grille) 370-H500-G)

Pressure Drop (core only)

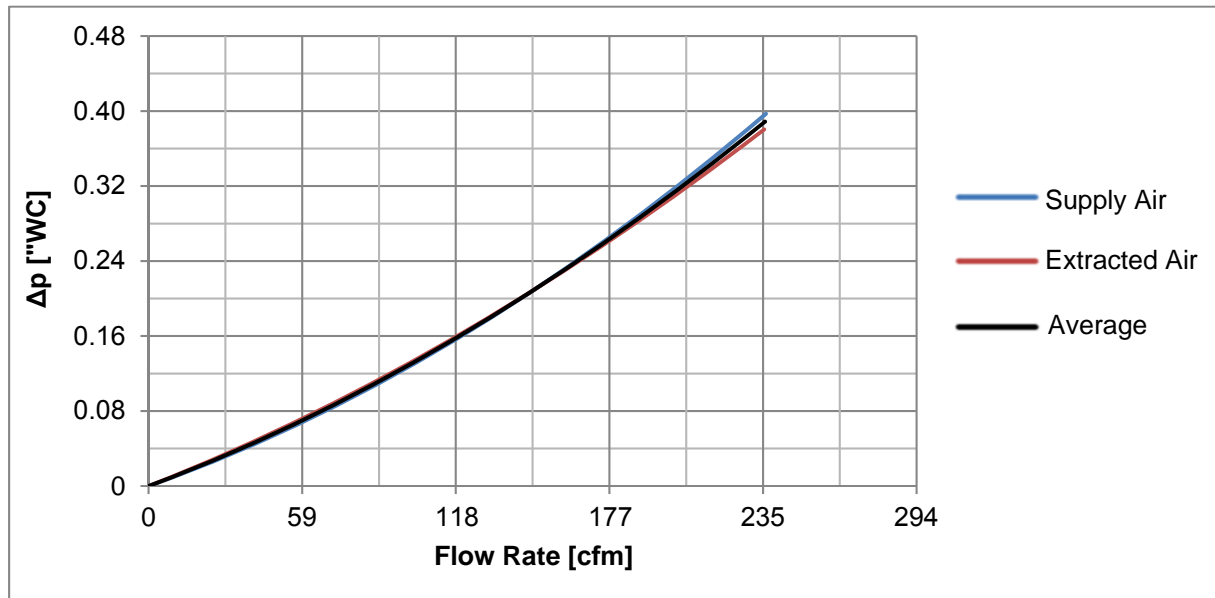

Recovery Efficiency (core only)

Flow Rate [cfm]	59	118	177	235
Sensible Recovery Efficiency [%]				
Supply	95.2	92.4	90.2	88.3
Extracted	91.3	89.2	87.3	84.7
Average	93.2	90.8	88.7	86.5
Latent Recovery Efficiency [%]				
Supply	N/A	N/A	N/A	N/A
Extracted	N/A	N/A	N/A	N/A
Average	N/A	N/A	N/A	N/A
Enthalpy Recovery Efficiency [%]				
Supply	74.5	71.1	69.5	68.1
Extracted	72.8	70.1	68.2	66.2
Average	73.7	70.6	68.9	67.1

Dimensional drawings

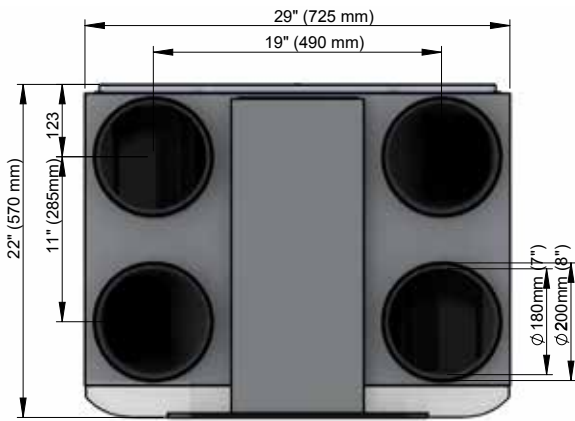

Top

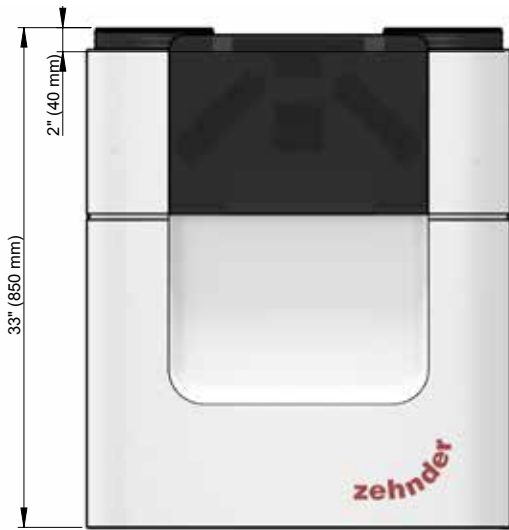

Front

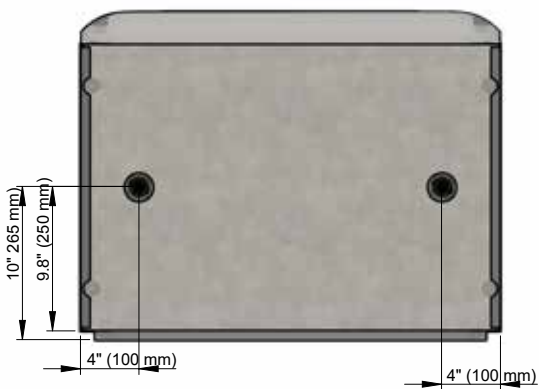

Bottom

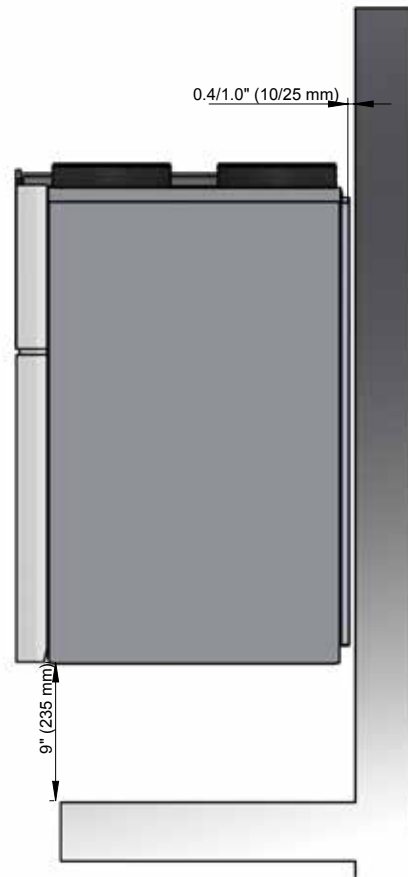

Side

Air directions

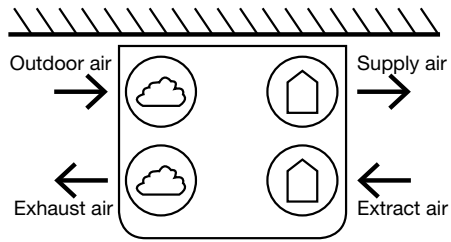

Supply and extract air to right

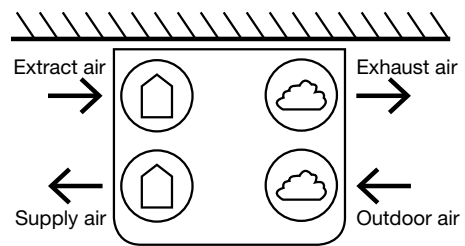

Supply and extract air to left